

## Section 9.4

# Electric Power Generation

*So far in this chapter, we have looked at what electricity is and how it's distributed. In this section, we'll discuss how it's generated. We'll see how fossil fuels such as coal, oil, and natural gas are used to produce mechanical motion and how that mechanical motion is used to produce electric power. We'll also examine solar and wind power generation.*

**Questions to Think About:** *How can a moving object push electric charges through a wire and produce electricity? Why are generating plants often built near bodies of water? What is the purpose of the giant cooling towers near some power plants? How does a power plant determine how much power it needs to generate, and what happens to its generators when the demand for power suddenly increases or decreases?*

**Experiments to Do:** *There are a few household generators. One of these is a bicycle generator, a small device that uses the rotation of a bicycle's wheels to produce electricity for its lamp. Find a bicycle generator and turn its rotor (its central spindle) with your fingers. You will find that the rotor spins relatively easily when the generator is disconnected from the lamp but becomes much harder to turn when the generator is powering the lamp. The rotor contains a magnet, which moves near several coils of wire as the rotor spins. These coils can only carry current when they're connected in a circuit. How does that need for a circuit explain why the rotor is harder to turn when the generator is connected to the lamp? What is the relationship between the work you do on the generator and the power consumed by the lamp?*

## Generating Electric Currents

In Section 9.2, we saw that a change in the magnetic flux passing through a transformer's secondary coil causes current to flow in that coil. Since the magnetic flux through the secondary coil changes whenever the current through the primary coil changes, an alternating current in the transformer's primary coil induces an alternating current in its secondary coil.

But there's another way to change the magnetic flux passing through a coil of wire: move the magnetic flux. That's how a generator works. Whenever a magnet moves past a coil of wire or a coil of wire moves past a magnet, the flux through the coil changes and current flows in the coil and its circuit.

Most generators use rotary motion to produce electricity. The generator shown in Figs. 9.4.1a and 9.4.2 has a permanent magnet that spins between two fixed coils of wire. As the magnet spins, its magnetic flux lines sweep through the two coils and drive a current through them. This current experiences a voltage rise as it passes through the coils and a voltage drop as it passes through the light bulb, so it transfers power from the generator to the bulb.

The iron core inside each coil extends the magnet's flux lines so that they are sure to sweep through the coil each time a pole of the magnet passes by. These cores are temporarily magnetized by the nearby magnet and effectively increase its length (Fig. 9.4.1a). Without the iron cores, most of the rotating magnet's flux lines would bend around before passing through the entire coil (Fig. 9.4.1b) and the generator would be less effective at producing electricity.

A generator of this type produces an alternating current in the circuit it powers. This current flows in one direction as the magnet's north pole approaches a coil and in the opposite direction as the south pole approaches it. To generate the 60 Hz alternating current used in the United States, the generator must turn 60 times each second so that the current completes one full cycle of reversals every  $1/60$ th of a second. In Europe, the generator must turn 50 times each second to supply 50 Hz alternating current. The generators throughout the continent-wide power distribution networks all turn together in perfect synchronization. That way, power can be redirected within each network so that any generator can provide the power consumed by any user.

Some devices require direct current electric power. A car is a good example. It generates DC electric power to charge its battery and to run its headlights, ignition system, and other electric components. While this power is actually produced by an AC generator or *alternator*, the car uses special electronic switches to send current from the alternator one way through its electric system. While the current in the alternator's coils reverses, the current through the car's electric system always travels in one direction.

Because large permanent magnets are extremely expensive, most industrial generators actually use iron-core electromagnets instead. These rotating electromagnets drive currents through generator coils just as effectively as permanent magnets would. Although these electromagnets consume some electric power, they are much more cost effective than real permanent magnets.

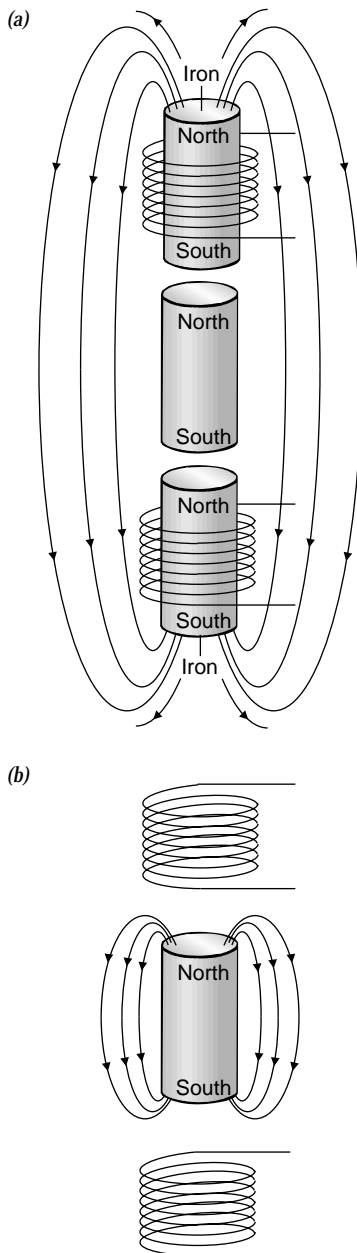

Fig. 9.4.1 - (a) As the rotating magnet of a generator turns, it periodically aligns with iron cores inside the generator's coils and temporarily magnetizes those cores. The changing flux through the cores and coils induces currents in the coil and generates electricity. (b) Without the iron cores, few of the flux lines from the rotating magnet would pass through the generator's coils.

### CHECK YOUR UNDERSTANDING #1: Lights Out at the Stop Sign

When a wheel-driven generator powers a bicycle light, the light turns off when the bicycle comes to a stop. Explain.

## Using Steam to Turn a Generator

Since the electric current extracts energy from the generator, something must do work on it to keep it turning. We can see why this work is needed by looking again at Fig. 9.4.2. As the permanent magnet turns its north pole toward the iron core above it, that core temporarily becomes magnetic with its south pole down. Opposite poles are then near one another and the permanent magnet is attracted toward the iron core. This attraction does (positive) work on the turning permanent magnet as the two poles approach but it also does negative work on the permanent magnet as the two poles separate. Overall, the iron core does zero net work on the permanent magnet.

But when the generator's coils are connected as part of a complete circuit, the currents induced in those coils make them magnetic, too. As required by Lenz's law, each magnetized coil repels the approaching permanent magnet. This effect is identical to the one we observed in electrodynamically levitated trains. An approaching magnet is always repelled by the currents it induces.

While a magnetized coil repels the turning permanent magnet, both as it approaches and as it leaves, the net work done by this repulsion isn't necessarily zero. If the current passing through the coils diminishes during the time between the permanent magnet's approach and its departure, the coil will repel the permanent magnet more strongly as it approaches than as it leaves and the net work done on the permanent magnet will be negative. Some of the permanent magnet's energy will be transferred to the electric current, which will deliver it to the devices in the circuit. The more power these devices extract from the circuit, the more work the permanent magnet must do to keep the current flowing.

Since the permanent magnet loses energy to the electric current, something must exert a torque on it to keep it turning. While small generators are often turned by hand cranks, pedals, or internal combustion engines, most large power plant generators are driven by steam turbines. We encountered turbines in Section 5.3, where they appeared in jet engines. But instead of deriving their power from burning aviation fuel, power plant turbines operate on steam (Fig. 9.4.3).

A turbine resembles a fan run backward. While a fan uses rotary motion to push air from low pressure to high pressure, a turbine uses the flow of steam from high pressure to low pressure to propel a rotary motion. High-pressure steam exerts unbalanced pressures on the turbine blades and those blades rotate away from the steam. Since the steam's force and the direction of motion are both in approximately the same direction, the steam does work on the turbine and provides the ordered energy needed to spin the generator's permanent magnet.

This ordered energy comes from the steam's thermal energy. But as we saw in Chapter 6, thermal energy can't be converted directly into ordered energy. The steam turbine must and does operate as a heat engine, converting a limited amount of thermal energy into ordered energy as heat flows from a hotter object to a colder object. In the steam turbine, the hotter object is the high-pressure steam and the colder object is the outside air or water. As the steam's heat flows toward the colder world around, nature and thermodynamics allow us to extract some of that heat as ordered mechanical energy.

A steam turbine is ideally suited to electric power generation because both involve rotary motions. The shaft of the turbine, on which its blades are fastened, experiences a torque from the steam and transfers that torque to the generator. The turbine and the generator's permanent magnet rotate together, with power flowing from the high-pressure steam, to the turbine blades, to the shaft, to the permanent magnet, and finally to the electric current flowing through the generator (Fig. 9.4.4). The turbine spins at a steady, regulated rate to produce 60 Hz alternating current in the United States and 50 Hz in Europe.

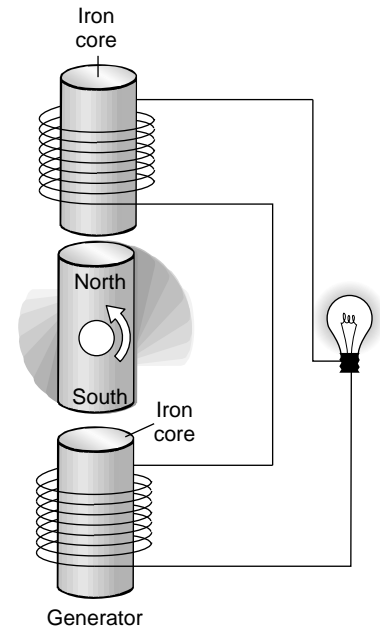

Fig. 9.4.2 - A generator works by sweeping magnetic flux through wire coils. Here a rotating magnet moves its flux past two coils and provides power to the electric circuit and the light bulb.

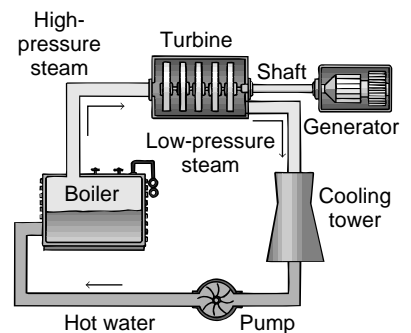

Fig. 9.4.3 - A steam turbine extracts work from steam as that steam flows from a high-pressure boiler to a low-pressure cooling tower. The cooling tower condenses the steam into hot water, which is then pumped back into the boiler.



Fig. 9.4.4 - A high-pressure steam turbine drives this electric generator, producing roughly 100 MW of electric power.

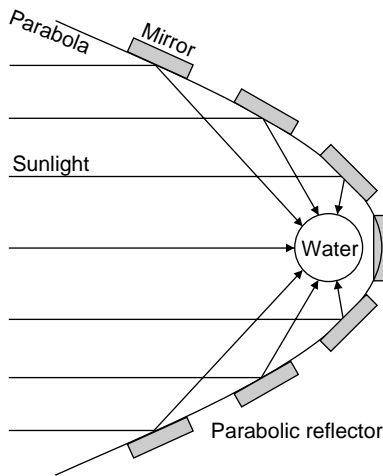

Fig. 9.4.5 - An array of mirrors can concentrate the sun's light onto a black tube containing water. The sunlight striking each mirror is redirected toward the water-filled tube. Here the mirrors form a parabolic arc and the tube rests at the focus of the parabola.

Fig. 9.4.6 - This solar electric power plant in the Mojave Desert uses curved mirrors to concentrate sunlight onto oil-filled pipes. The hot oil is then used to boil water and generate electricity.

### CHECK YOUR UNDERSTANDING #2: Light Work

When you turn a bicycle generator rapidly by hand, you can tell whether it's part of a completed circuit. If it isn't part of a circuit, the generator turns relatively easily. If it is, the generator is hard to turn. Why?

## Heating and Cooling the Steam

Steam is produced in a boiler, where thermal energy is added to liquid water until its molecules separate into a dense, high-pressure gas. The hotter the steam, the higher its pressure and the more effective it is at spinning the turbine. This thermal energy can come from burned fossil fuels, from a nuclear reactor (see Section 14.3), or from sunlight.

As the steam flows through the turbine and does work on the rotating blades, its pressure and temperature drop. By the time the steam leaves the turbine, it has cooled considerably and its pressure is only slightly above atmospheric. It's time to return it to the boiler for reuse. But the steam must first be converted back into water because the work required to pump steam into the boiler is proportional to its volume. Turning the steam into dense liquid water reduces that work enormously.

The low-pressure steam flows through a cooling tower, where it gives up heat to the surrounding air. Often that heat is used to evaporate additional water, which then condenses in the cooler air above the tower as a plume of white mist. Once the steam has given up enough heat, it condenses into water and can be returned to the boiler. Many power plants are built near large bodies of water, which also receive some of the steam's waste heat. And a few modern power plants use this waste heat for other industrial or commercial purposes such as heating buildings.

Virtually any source of heat can be used to generate electricity. Recently, power plants have been built that use sunlight to produce steam. The sun's thermal radiation delivers about 1,000 W of heat to each  $\text{m}^2$  of the earth's surface. While that isn't enough heating for a normal boiler, concentrated sunlight can boil water fast enough to produce high-pressure steam. Most thermal solar power plants use mirrors to concentrate sunlight onto their boilers.

We will examine mirrors more carefully in later chapters. What is important here is that mirrors redirect the path of light and can be used to concentrate sunlight onto a boiler. One possible arrangement of mirrors is the parabolic reflector (Figs. 9.4.5 and 9.4.6). A parabolic mirror can take all of the light from one



distant source (e.g. the sun) and focus that light together. If the mirror is parabolic all the way around, like a bowl, then it focuses light to a single spot. If it's parabolic only in one direction and extends as a trough in the other direction, then it focuses light to a line. In either case, it can concentrate sunlight tightly enough to boil water, produce steam, and operate a turbine.

One other interesting source of heat for a steam turbine is geothermal power. In many regions of the world, the earth's outer crust is relatively thin and high temperatures are found close to the earth's surface. Water sent far down into the ground returns to the surface as hot, high-pressure steam, which can be used to generate electricity. Natural geysers use a similar technique to produce beautiful jets of steam and water.

### CHECK YOUR UNDERSTANDING #3: Following the Flow of Energy

How is energy transferred and transformed as it moves through a coal-fired electric power plant, from ancient history to your reading lamp?

## Solar Cells

A second method of solar power generation is direct conversion of light into electricity by a *photoelectric cell* or photocell. A photoelectric cell uses light energy to pump charges from one of its terminals to the other. In effect, the photoelectric cell is a light-powered battery. But instead of using a chemical reaction to pump charges, as a normal battery does, the photoelectric cell uses light energy.

The photoelectric cell is built from semiconductors. When light strikes a semiconductor, that light can shift electrons from valence levels to conduction levels, so that the electrons can move through the material. As we saw in Section 8.2, this effect is the basis for xerography. Another consequence of light exposure is that electrons in the conduction levels can move from one part of the semiconductor to another, creating a temporary separation of charge. But such separations of charge are short lived because attractive forces between electrons and the positive charges they left behind quickly bring them back together.

To sustain these charge separations, the photocell must allow the electrons to flow in only one direction, so that they can't return to the positive charges. This one-way flow is achieved by turning the semiconductor into a diode. A **diode** is a one-way device for current, allowing it to flow only in one direction.

When light strikes a semiconductor diode and shifts some of its electrons to conduction levels, many of those electrons travel from the diode's electron emitting side, its **cathode**, to its electron-collecting side, its **anode**, and find it impossible to return. The anode becomes negatively charged while the cathode becomes positively charged and the diode begins to exhibit a voltage rise. It acts as a light-powered battery, a photoelectric cell.

As we will discuss in detail in Section 10.1, a semiconductor diode is made by joining two different semiconductor materials. These two materials are not pure semiconductors and don't have perfectly filled valence levels and perfectly empty conduction levels. They have been **doped** with atomic impurities that either place a few electrons in the conduction levels (**n-type semiconductor**) or leave a few of the valence levels empty (**p-type semiconductor**). These conduction level electrons or empty valence levels allow n-type and p-type semiconductors to conduct electricity, even in the dark.

But when a piece of n-type semiconductor touches a piece of p-type semiconductor, something remarkable happens (Fig. 9.4.7). Higher-energy conduction level electrons from the n-type semiconductor flow across the junction and fill in the empty lower-energy valence levels in the p-type semiconductor. Only a few

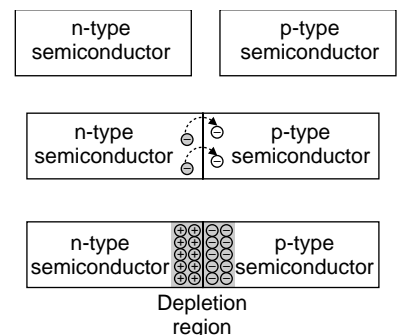

Fig. 9.4.7 - When p- and n-type semiconductors touch, conduction level electrons flow from the n-type material to the p-type material, creating a thin, electrically charged depletion region at the junction.

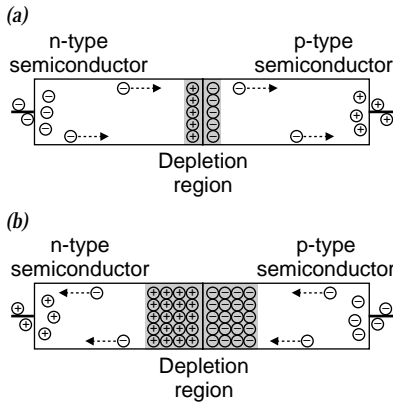

Fig. 9.4.8 - (a) When you add positive charges to the p-type side of a p-n junction and negative charges to the n-type side, the depletion region thins and current can flow across the junction. (b) Reversing the charges thickens the depletion region so that no current can flow across the junction.

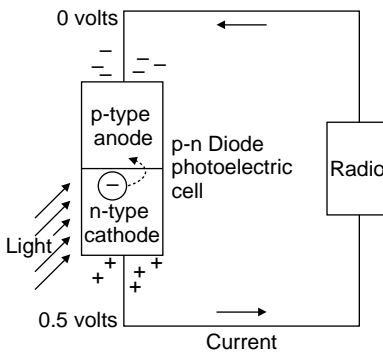

Fig. 9.4.9 - When light strikes a p-n junction, negative charge accumulates on its anode and positive charge accumulates on its cathode. A current flows in the circuit, obtaining power from the photocell and delivering it to the radio.

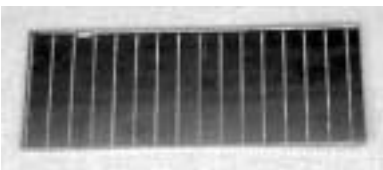

Fig. 9.4.10 - This solar cell is a diode that uses light energy to pump electrons from its n-type cathode (bottom surface) to its p-type anode (top surface). The thin metal strips on the anode collect those electrons while leaving most of the semiconductor surface exposed to light.

electrons move because they create a charge imbalance when they do. The n-type semiconductor then has too few electrons and a positive charge. The p-type semiconductor then has too many electrons and a negative charge.

A depletion region forms near the **p-n junction**, the place at which the p-type and n-type materials meet. Within this **depletion region**, the extra conduction level electrons from the n-type material fill the empty valence levels in the p-type material. With no conduction level electrons or empty valence levels left, the depletion region can't conduct electricity and charge can't move across the p-n junction.

However, when you attach wires to the diode and use them to add negative charge to the n-type material and positive charge to the p-type material, the depletion region becomes thinner (Fig. 9.4.8a). The added negative charge on the n-type material pushes conduction level electrons toward the depletion region and the added positive charge on the p-type material pulls valence level electrons away from the depletion region. As they thin the depletion region, these added charges also create a voltage drop across the p-n junction. When this voltage drop reaches about 0.6 V (for a silicon diode), the depletion region becomes so thin that conduction level electrons in the n-type material begin to flow across the junction into empty valence levels in the p-type material and the p-n junction conducts electric current.

The reverse happens when you add positive charge to the n-type material and negative charge on the p-type material (Fig. 9.4.8b). In that case, the depletion region becomes thicker as the added positive charge on the n-type material pulls conduction level electrons away from the depletion region and the added negative charge on the p-type material pushes valence level electrons toward the depletion region. The depletion region continues to prevent charge from moving and no current flows across the p-n junction.

Since it allows current to flow in one direction but not the other, the p-n junction is a diode. It can also act as a photocell. Photons (light particles) with enough energy can propel conduction level electrons across the depletion region from the n-type material to the p-type material. Once they have made this trip, these electrons can't return. The p-type material becomes the diode's negatively charged anode and the n-type material becomes the positively charged cathode.

When exposed to light, a photocell can pump current through a circuit (Fig. 9.4.9). As this current passes from the anode to the cathode, it receives power from the photocell and experiences a voltage rise of about 0.5 V. It then delivers this power to the rest of the circuit. To obtain the larger voltage rises needed to power some devices, several photocells can be connected in a chain, just like batteries in a flashlight.

Photocells are usually made from thin sheets of highly purified silicon (Fig. 9.4.10). These sheets are chemically treated so that one surface is p-type and the other n-type, with a p-n junction between them. Unfortunately, fabricating such photocells is difficult and costly because it requires technology similar to that used in fabricating silicon computer chips.

A typical solar-powered house would require many square meters of photocells, even in a sunny climate. If solar cells cost as much as computer chips, solar power would be prohibitively expensive. Fortunately, new techniques continue to simplify the fabrication of photocells and reduce their costs. Moreover, sunlight can be concentrated with mirrors or lenses so that smaller photocells can be used efficiently. Photocells are approaching the point of being cost effective for electric power generation on an industrial scale.



**CHECK YOUR UNDERSTANDING #4: It's a One Way Street**

What will happen if you include a p-n junction (a diode) in the AC circuit that connects the power company to your table lamp?

## Wind and Water Power

Wind and water are also used to generate electricity. In a wind turbine, moving air exerts a torque on the turbine, which in turn spins a generator. The wind slows down while doing work on the turbine, as the generator transfers its energy to the electric current.

Wind power generating stations can be seen at various places in the United States, particularly in California. Sometimes whole hillsides are covered with wind turbines, all turning together. Their synchrony is more than an aesthetic issue. Each generator produces 60 Hz alternating current (50 Hz in Europe), so it must turn at just the right rate or it will be in conflict with the electric power network to which it's connected. A private wind generator can turn at whatever rate its owner chooses, but an industrial wind generator must turn at the rate specified by the power network.

Moving water, or water that is descending from an elevated river or lake, can also do work on a turbine and generate electricity. The water's total energy, the sum of its gravitational potential energy, kinetic energy, and pressure potential energy, diminishes as the generator transfers energy to the electric current.

Hydroelectric generating facilities are as old as the use of alternating current itself, since alternating current first made it feasible to transport power from generating sites to relatively distant cities. When AC hydroelectric power from Niagara Falls arrived at Buffalo, NY in 1896, it marked the beginning of the end for Edison's DC power distribution systems.

**CHECK YOUR UNDERSTANDING #5: Worth the Weight**

Why are hydroelectric power plants built at sites where water undergoes large changes in height?